

Your parts

- 18. Brown thread 0.50mm
- G. Deadeyes (small)
- I. Trucks
- J. Long tackle blocks
- N. Brown thread 0.80mm

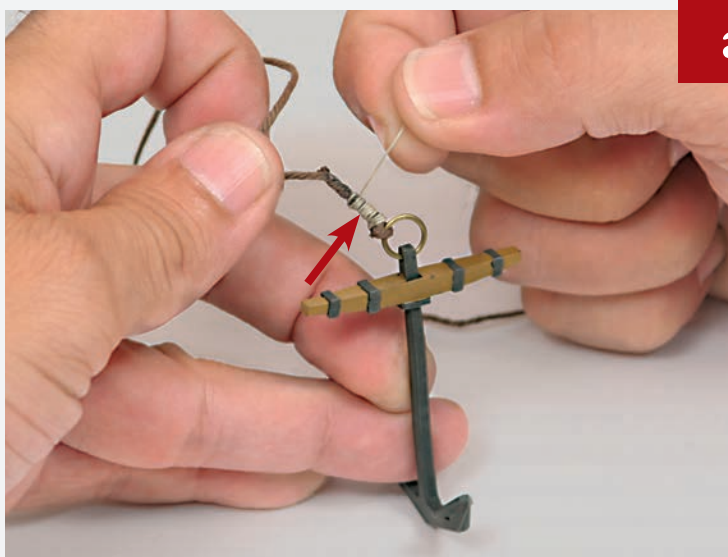

a

Take one of the anchors and bind the twisted length of threads with 0.15mm natural thread, as shown.

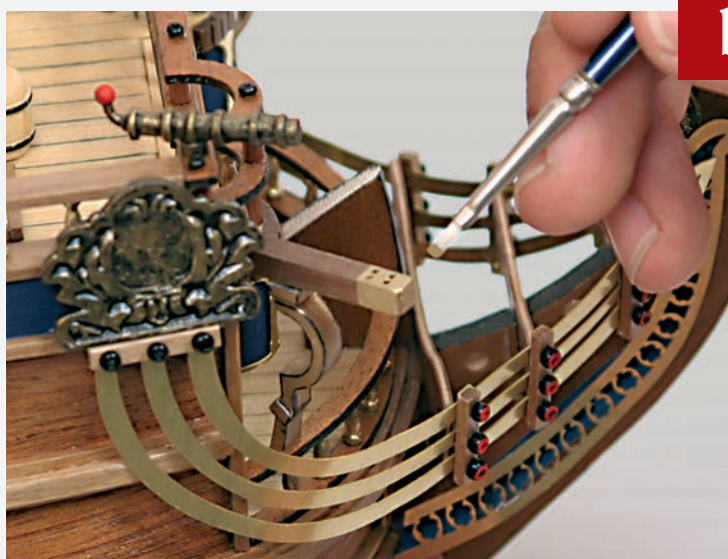

b

Paint the end of one of the bow davits with gold paint, ending just behind the drilled holes.



c

Drill a small hole halfway along the outer edge of the davit, taking care not to drill through to the other side.

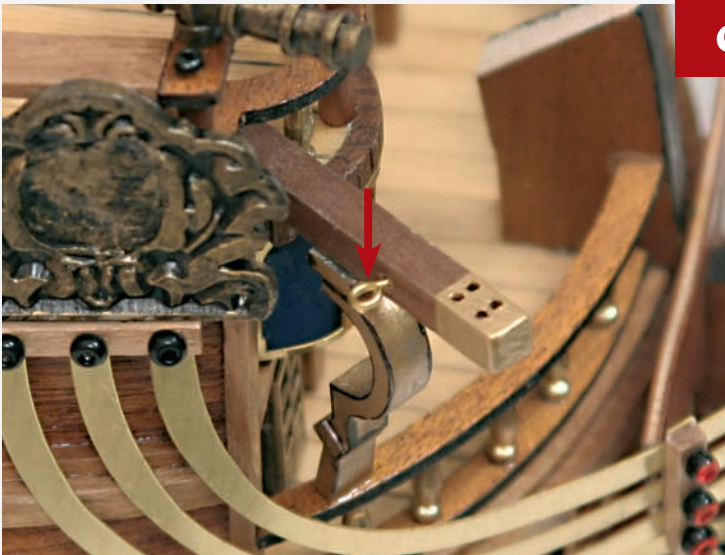

d

Glue an eyebolt into the hole drilled in the previous step, with the hole positioned horizontally.

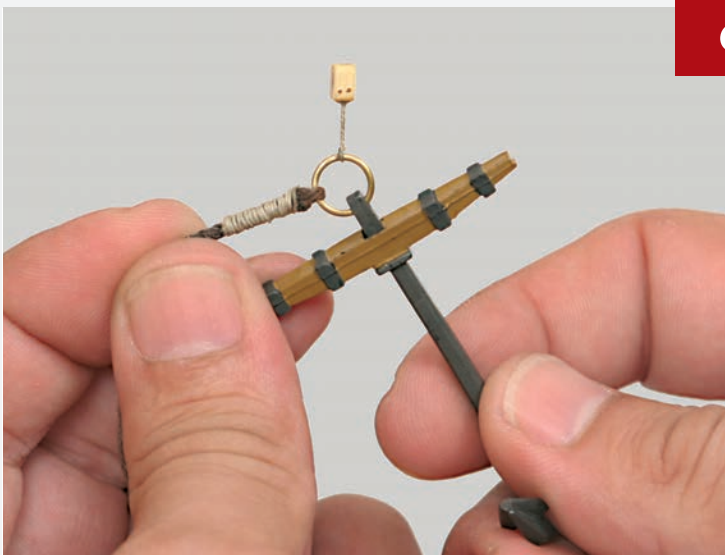

e

Tie a double block to the ring with 0.15mm natural thread.

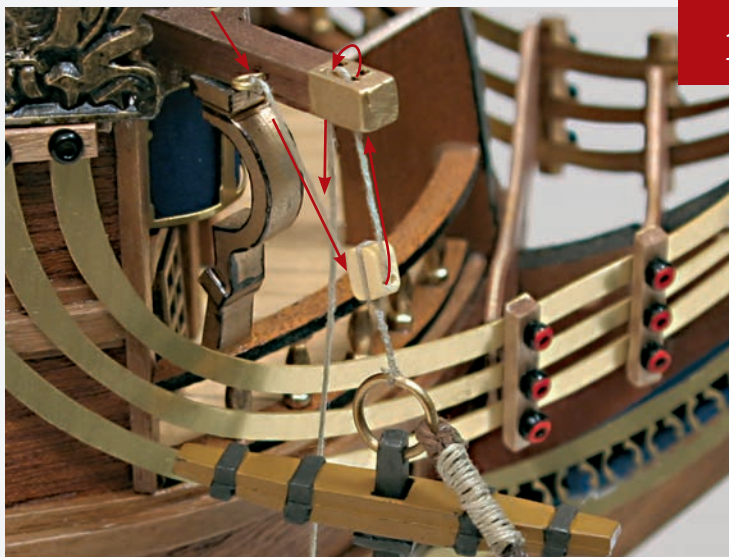

f

Cut a length of 0.15mm natural thread, tie one end to the eyebolt from Step d and pass the other end through the outer hole of the block. Then take that end up through the first outer hole of the davit and down through the second, following the arrows in the photo.

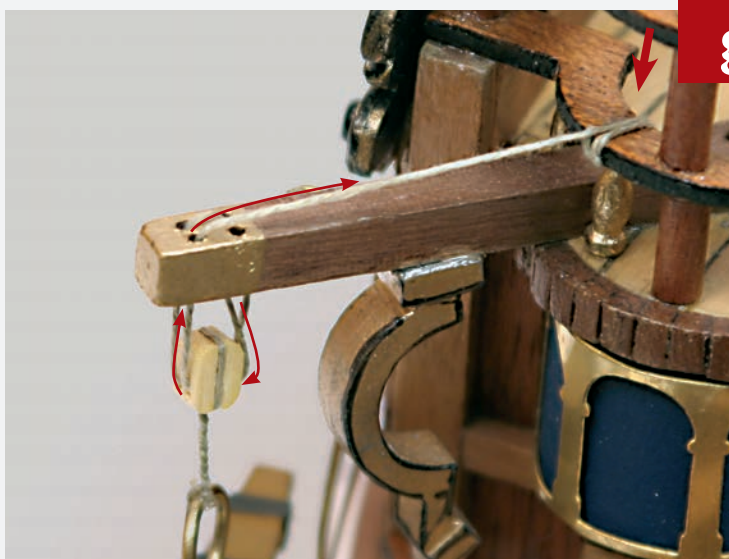

g

Pass the loose end of the thread through the inner hole of the block and up through the inner hole of the davit. Tie off the length of thread to the edging, as shown. Follow the arrows to help you.

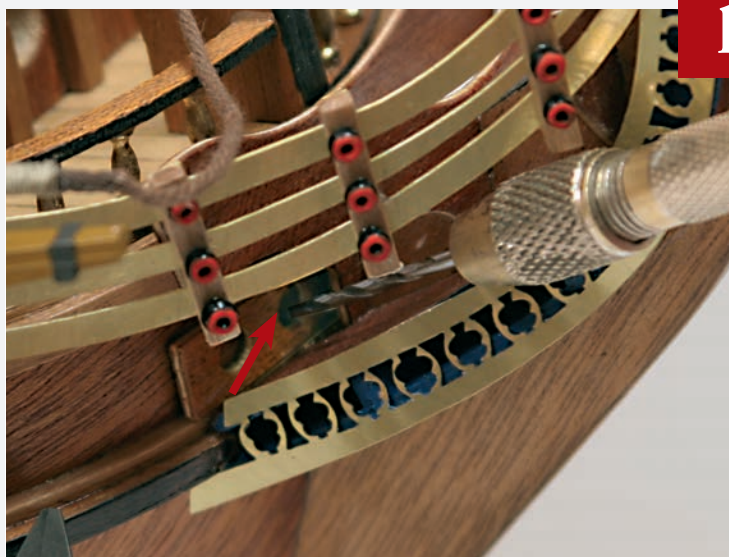

h

Drill a 2mm hole in the inner recess of the hawsehole (arrowed).

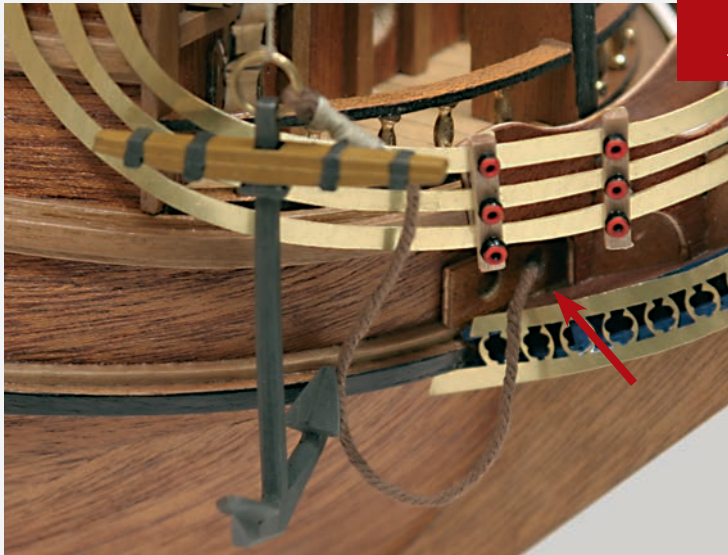

i

Hold the end of the brown thread from the anchor into the inner hawsehole. If it appears longer than shown in the photo, trim the end to get the correct length. Glue into place.



j

Repeat Steps a-i for the other side of the bow. Keep the two remaining anchors to one side; they will be fitted at a later stage.



k

The photo shows how the assembly should look at this stage. Keep any left-over material, as it will be used later.



Your parts

Mizzenmast plan

- 68. Mizzen lower mast
- 71. Crosstrees of the mizzenmast maintop
- 73. Mizzentop hounds
- 74. Mizzentop
- 76. Lower mast cap
- 78. Crosstree hounds
- 84. Crossyard jack
- 88. Mizzen topmast yard
- 89. Flagpole

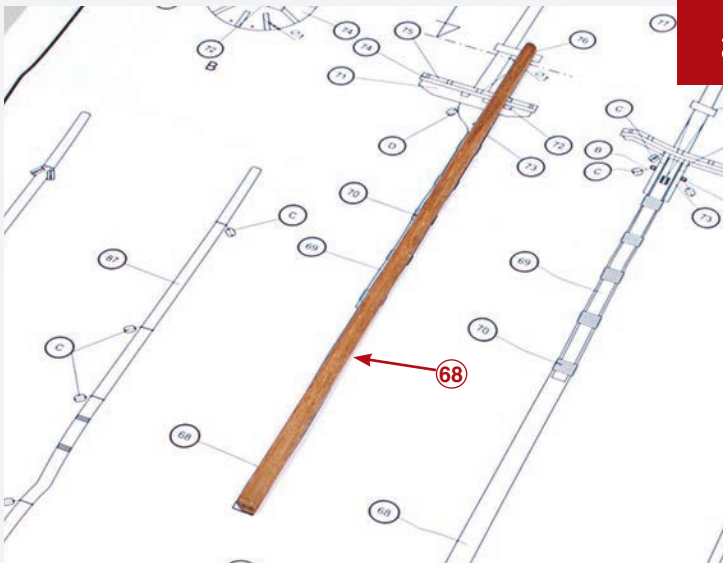
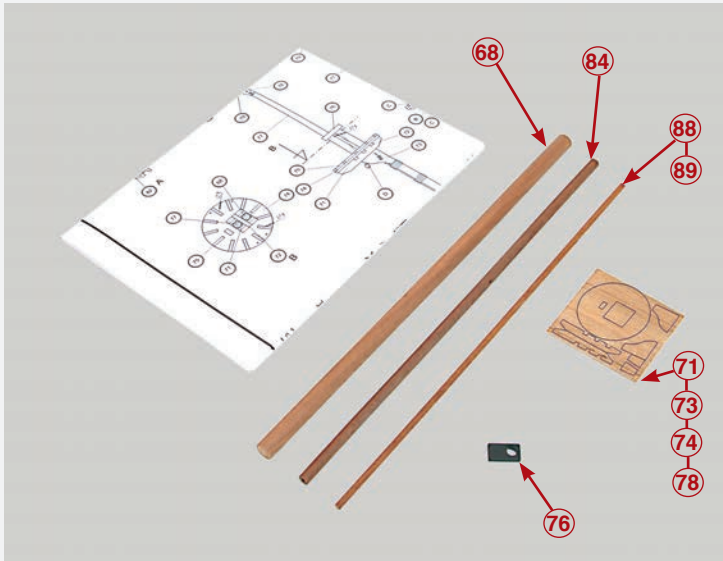

a

Prepare the mizzen lower mast by laying it on the plan, cutting it to length and tapering where necessary. Stain the mast before proceeding.

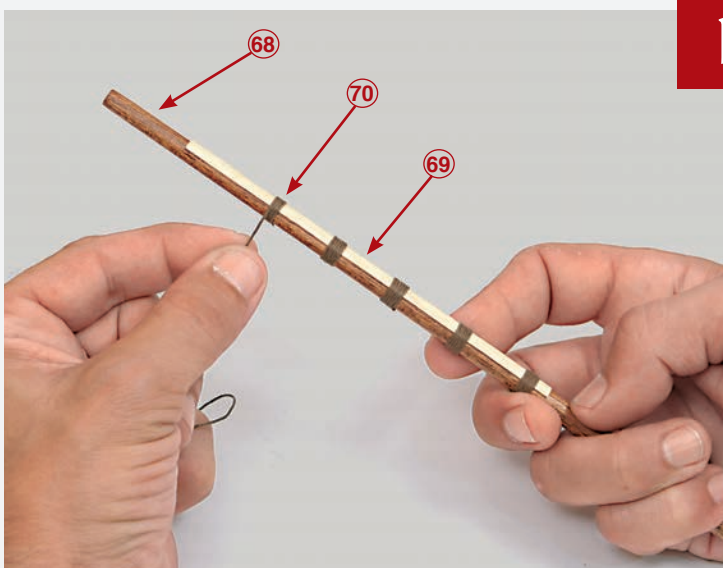

b

Glue the rubbing paunch, part 69, to the mizzenmast and bind into place with thread, part 70.

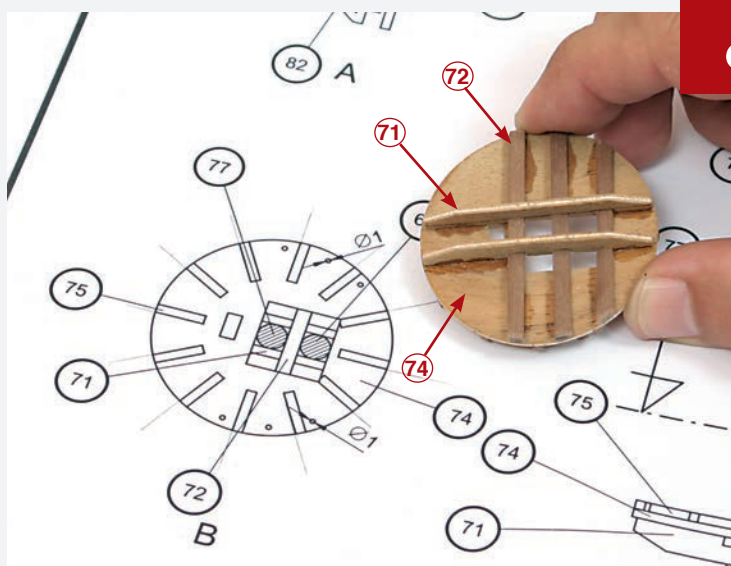

c

Assemble the underside of the mizzenmast maintop, part 74, by gluing parts 72 and 71, the trestle trees and crossrees, in place.

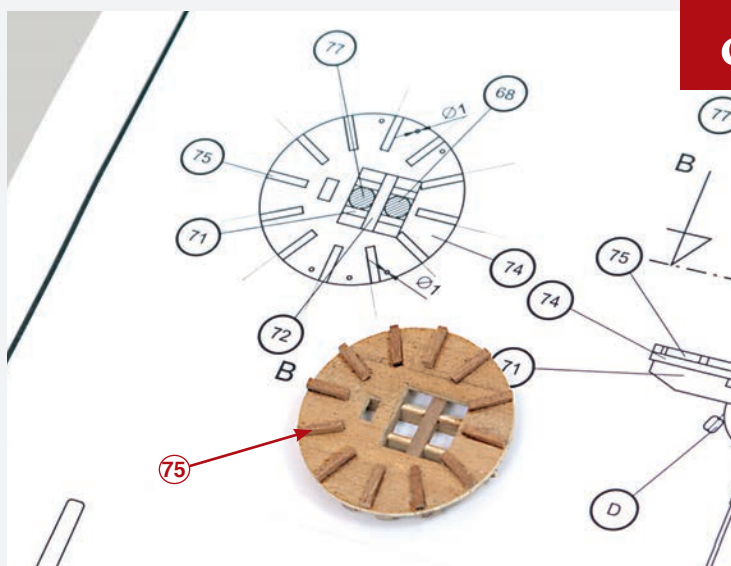

d

Turn over the mizzenmast maintop assembly and glue the 12 ribs, parts 75, into position as shown.

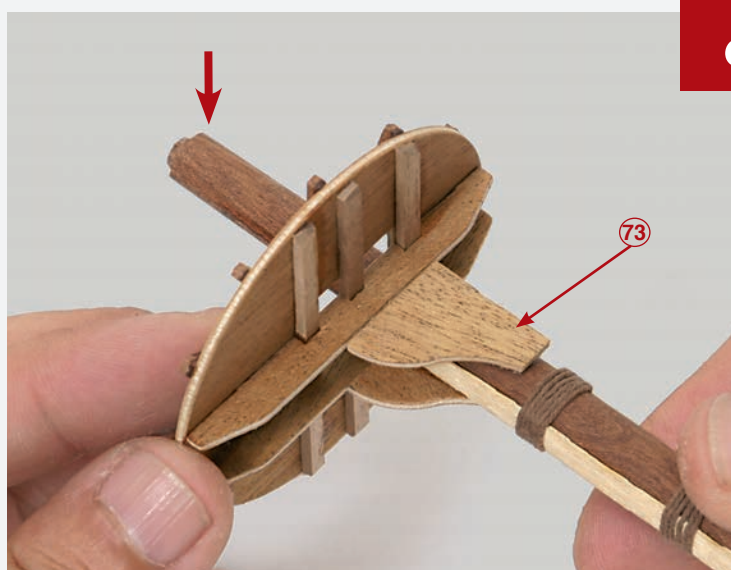

e

Temporarily place the mizzenmast maintop on the mizzen lower mast to locate the correct position for parts 73, the mizzenmast hounds, and then glue them into place.

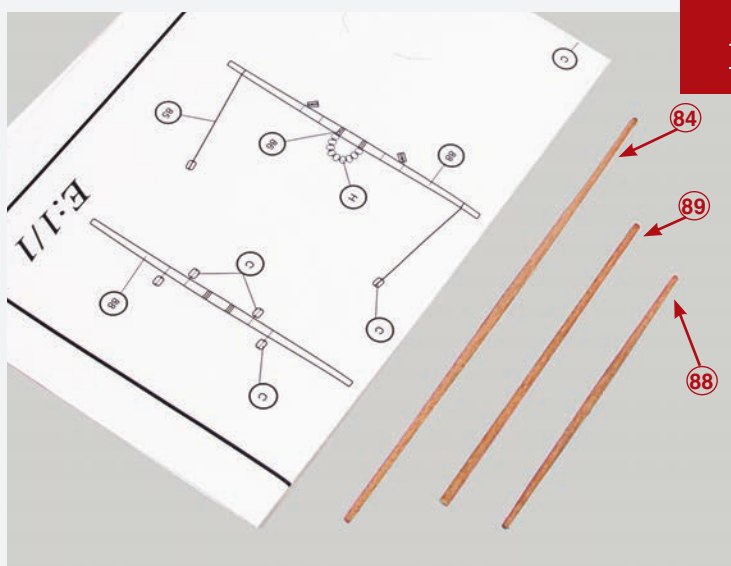

f

Prepare the two yards, parts 84 and 88, and the flagpole, part 89, using the plan as a guide. The mizzen topmast yard and the flagpole come from the same length of wood.

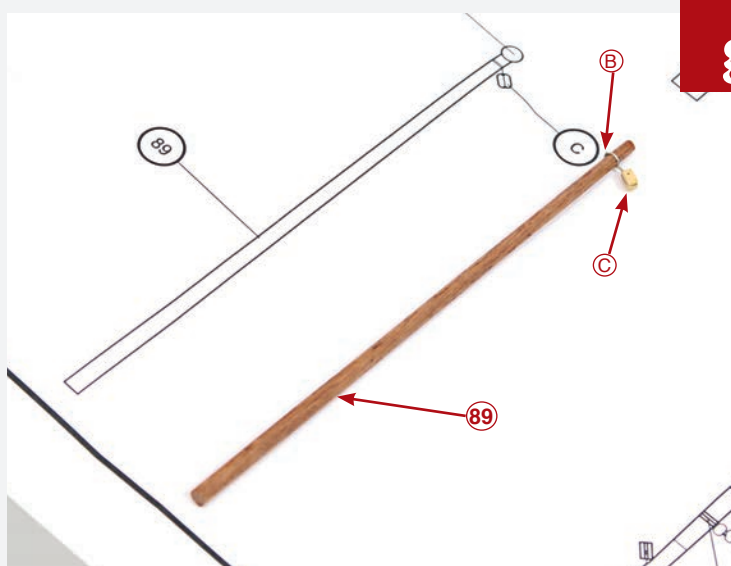

g

Tie a C block with thread B at the top of the flagstaff, as shown on the plan.

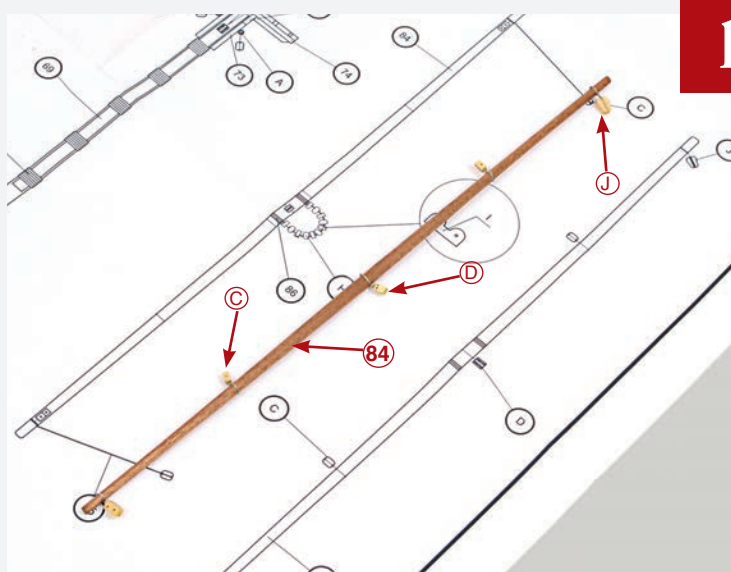

h

Tie two C blocks, two J blocks and one D block to the cross-jack yard, part 84, as shown in the photo and on the plan.

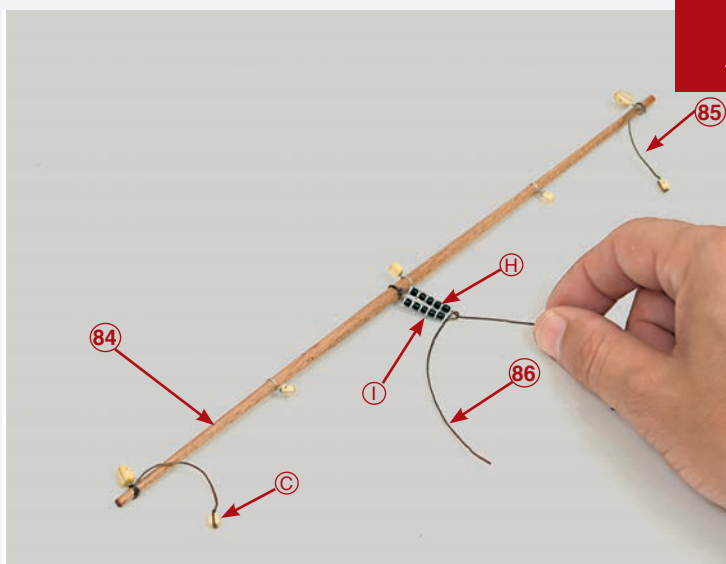

i

Use the plan to identify the blocks to attach to the cross-jack yard, and the corresponding threads with which to attach them. Once the blocks are fixed in place, attach the parrel, as on the previous yards.

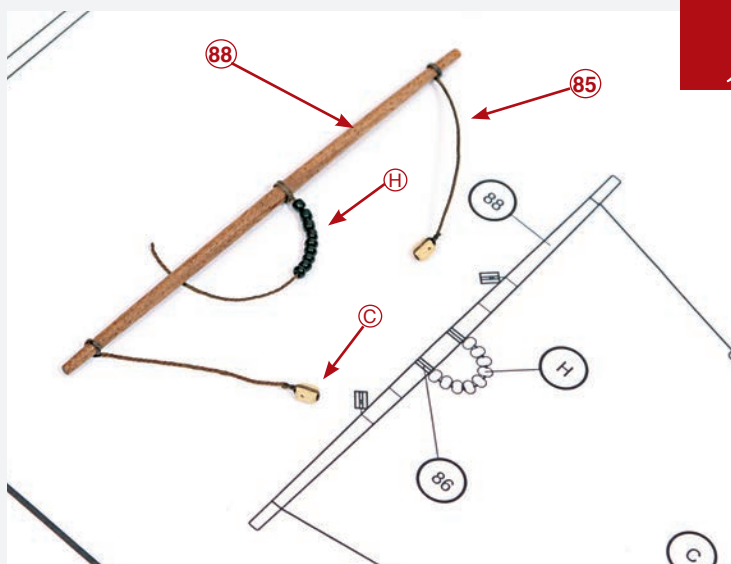

j

As shown in the photo, attach the parrel and two C blocks to the ends of the mizzen topmast yard.



k

The photo shows how the assembly should look at this stage. Keep any left-over material, as it will be used later.

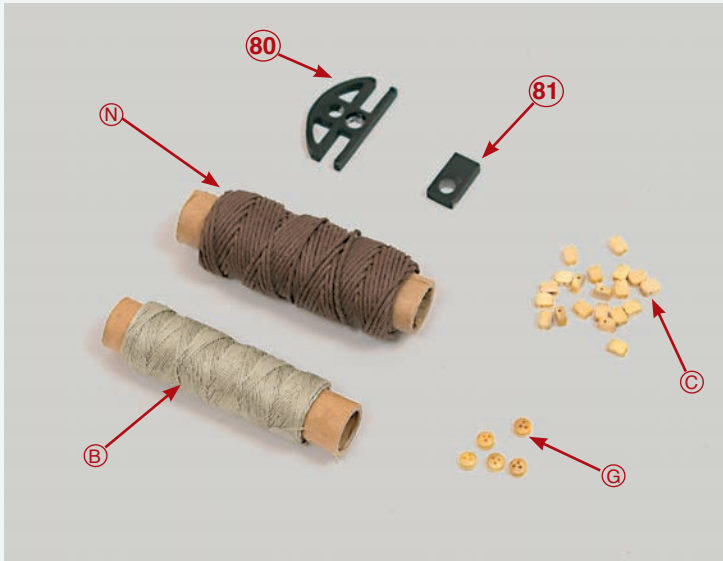

Your parts

- 80. Mizzen topmast crosstrees
- 81. Upper mast cap
- B. Natural thread 0.15mm
- C. Single blocks
- G. Deadeyes
- N. Brown thread 0.15mm

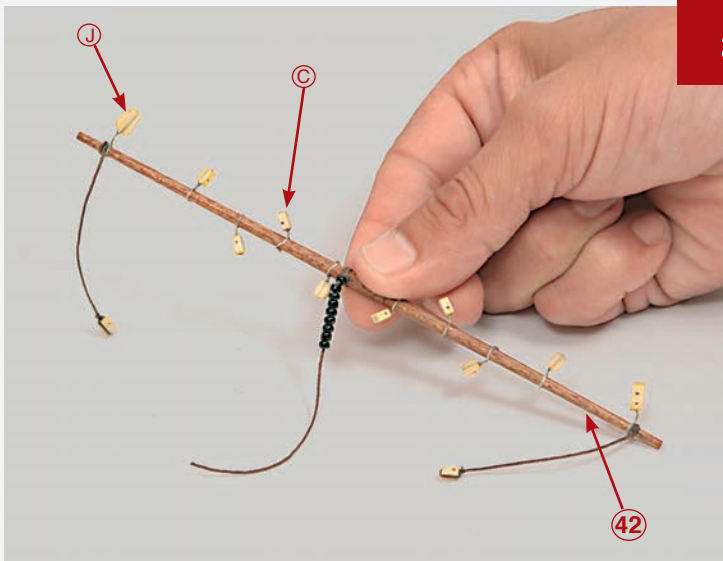

a

Complete the fittings for the fore topsail yard, adding the C and J blocks.

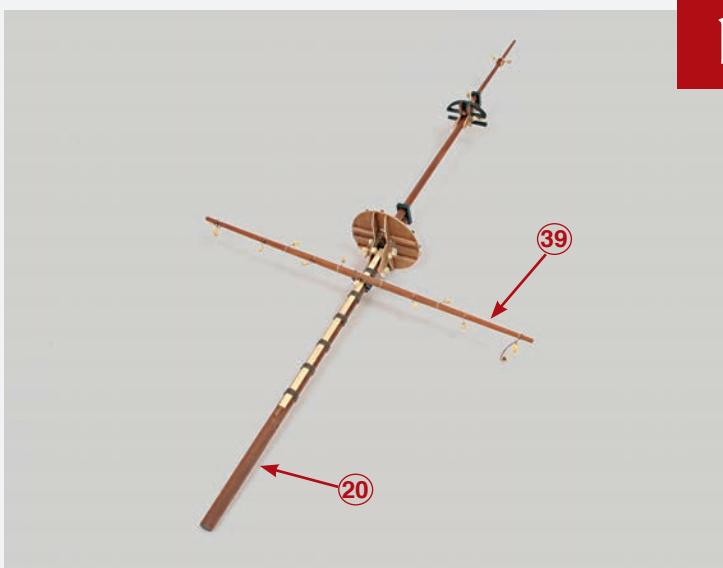

b

Lay the foremast down and use the plan to find the position for the fore yard. Tie the parrel around the mast to secure the yard in place.

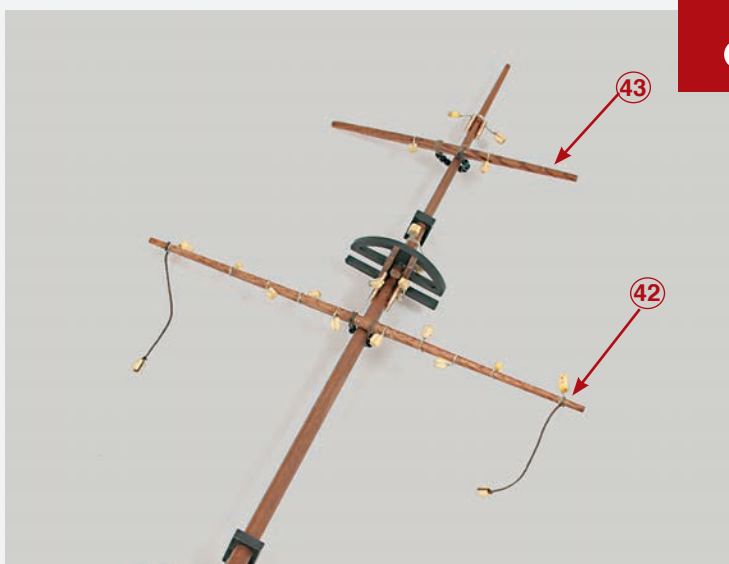

C

As in the previous step, fix the fore topsail yard and the fore topgallant yard to the foremast.

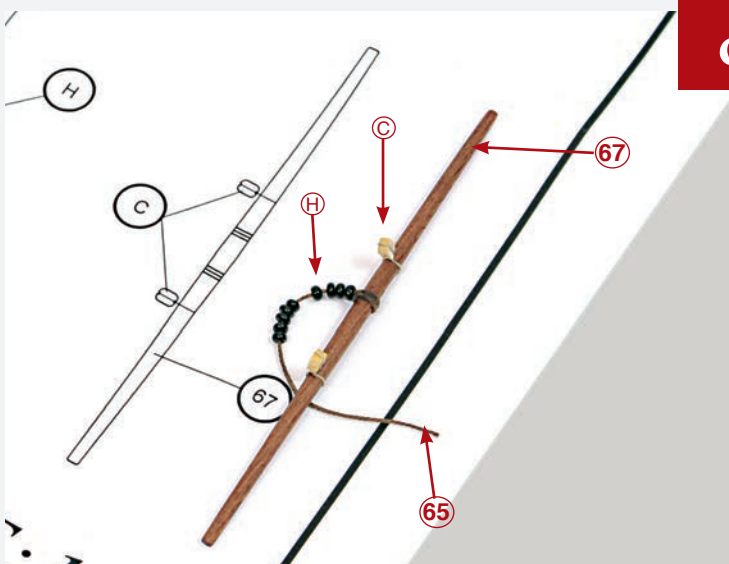

d

Fix the fittings (parrel and C blocks) to the main topgallant yard, as shown.

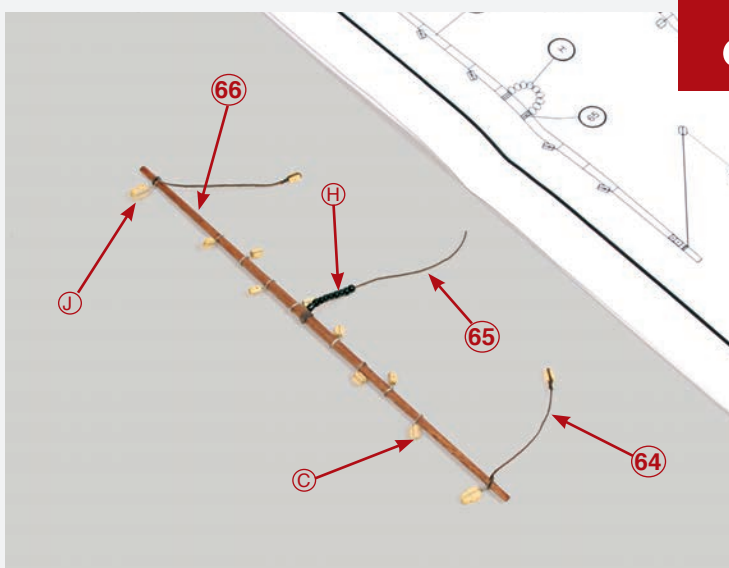

e

Fix all the fittings shown on the plan to the main topmast yard.

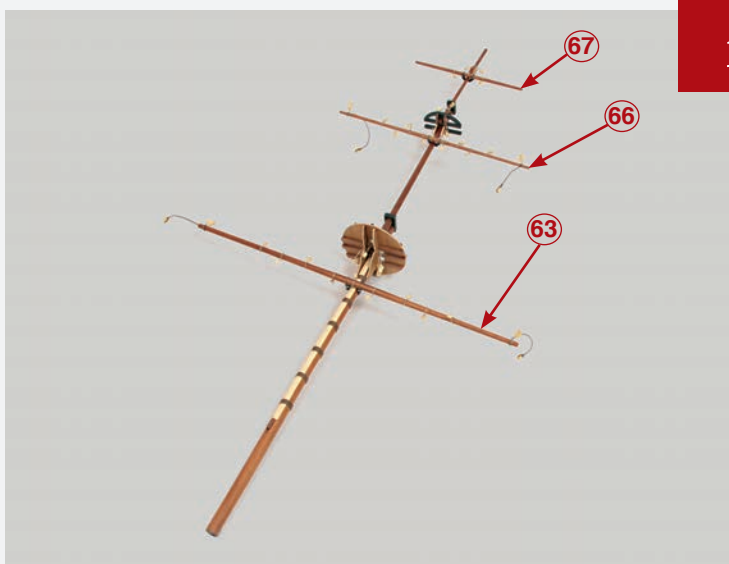

f

As in Steps b and c, fix the three mainmast yards, 63, 66 and 67, to the mainmast, as shown on the plan and in the photo.



g

Check that the masts fit in their holes. If not, take a round file and enlarge the hole until the mast fits securely in place.

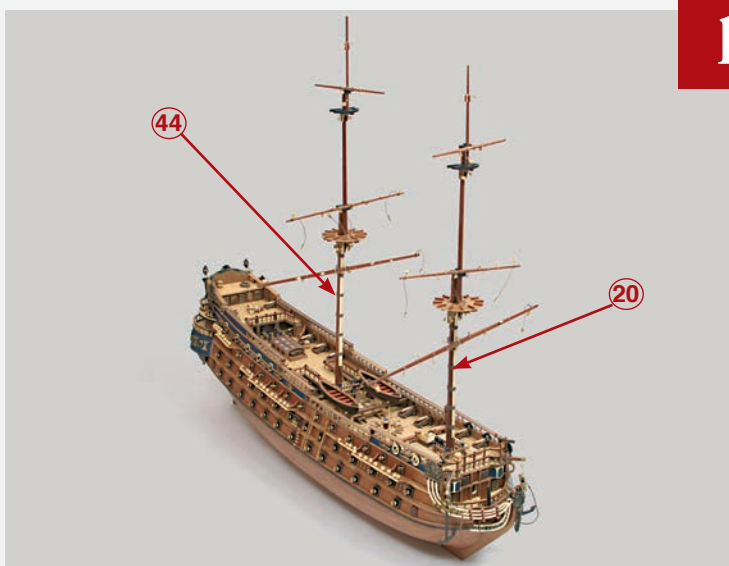

h

Stand the model upright. Slide the lower foremast (20) and the lower mainmast (44) into their holes until they stop. Adjust their position until they are vertical and then apply glue to the contact points between the masts and decks.

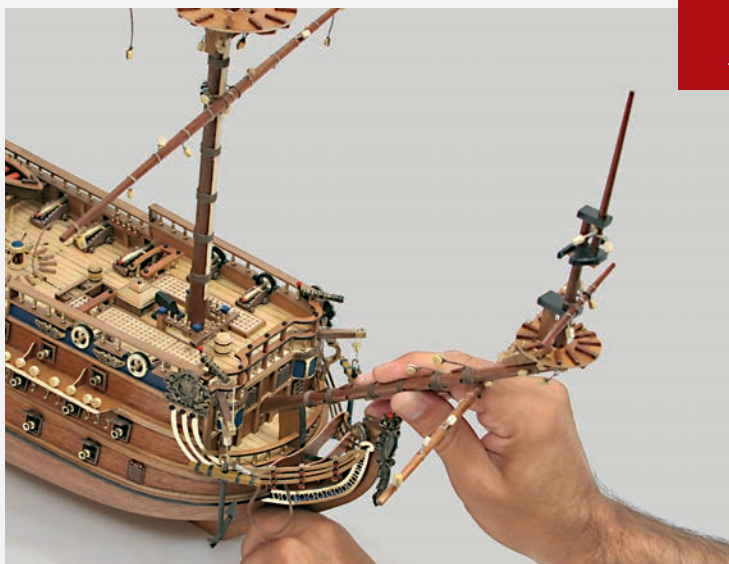

i

Slide the bowsprit into position until it comes to a stop. It should be vertically aligned with the other masts along the centre of the ship.



j

Use the 0.80mm brown thread to secure the bowsprit in position. Loop the thread over the bowsprit and through the corresponding hole in the beak below it, repeat this three times and tie off the thread in the centre with a double knot.



k

The photo shows how the assembly should look at this stage. Keep any left-over material, as it will be used later.

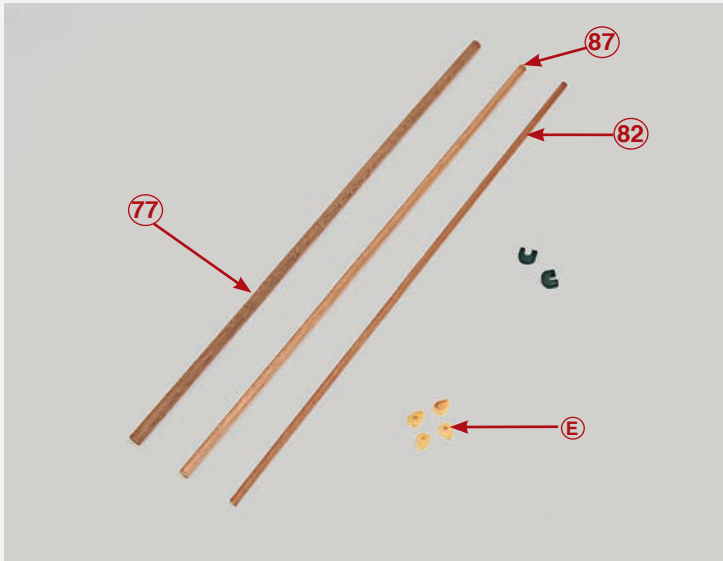

Your parts

- Flagpole supports
- 77. Mizzen topmast
- 82. Mizzen topgallant mast
- 87. Driver
- E. Heart block

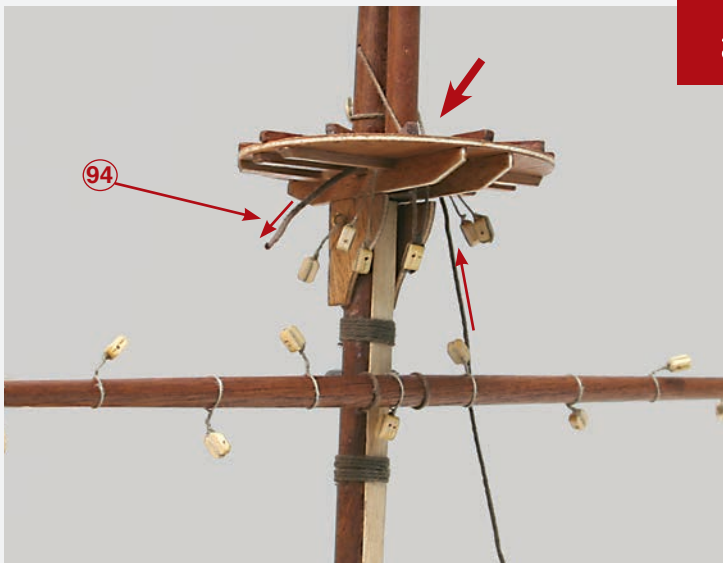

a

To begin rigging the shrouds, 94 and 97, in figure A on the rigging plan, pass a length of thread (94) through the hole in the foremast maintop from below, then pass it between the lower mast and the topmast and pull down through the other side of the top.

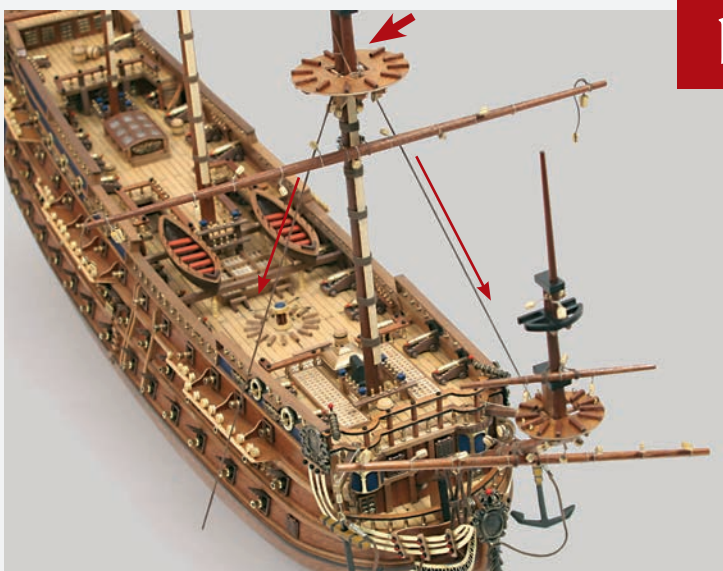

b

Pull the thread so its lengths are equal on both sides of the hull. Then apply glue to the crosstrees to secure it in place. The loose ends should be positioned behind the yard.

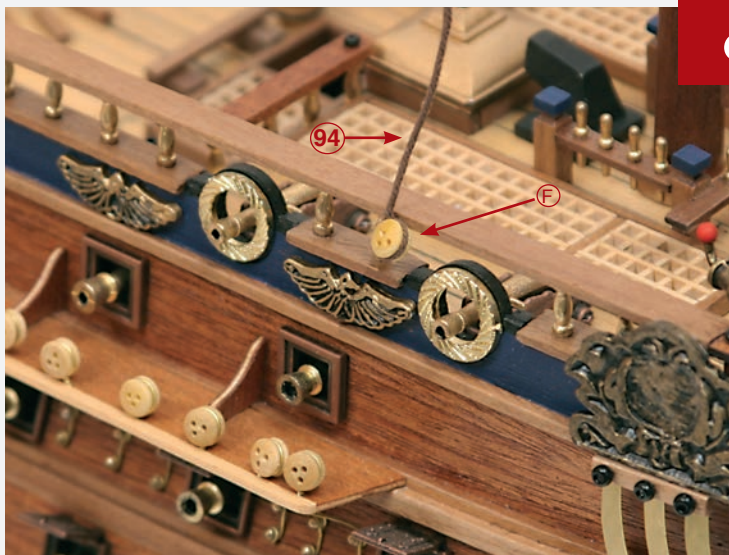

c

Tie an F deadeye (5mm) at each end of the thread. Once secure, cut off the excess thread. Always secure the knots with a dab of superglue.

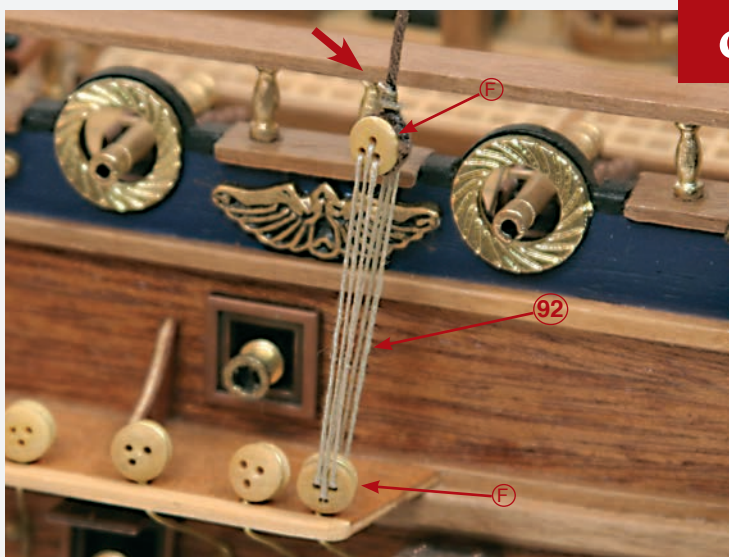

d

Follow the inset in figure A on the rigging plan, using 0.15mm natural thread (92), to connect the deadeyes together, as shown. Apply glue to the ends of the lanyards (92) to secure. Repeat for the other end of the thread.

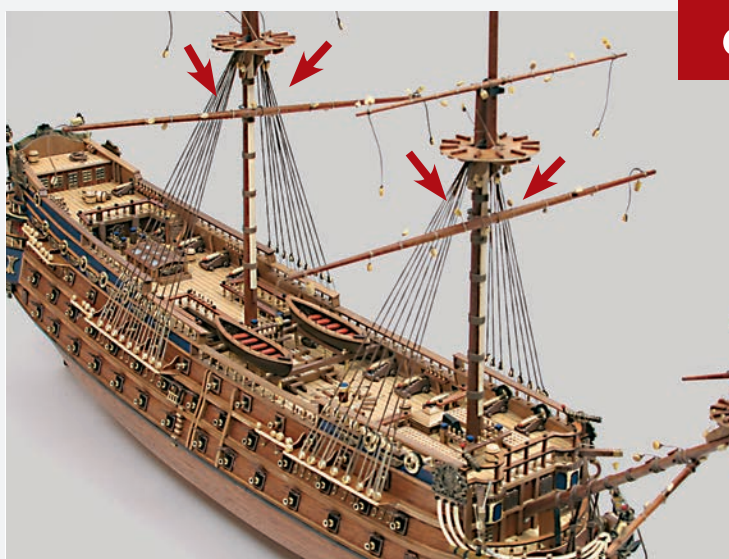

e

Repeat the process in Steps a-d to fit the remaining seven shrouds to the foremast and nine to the mainmast, and to link them to the corresponding deadeyes.

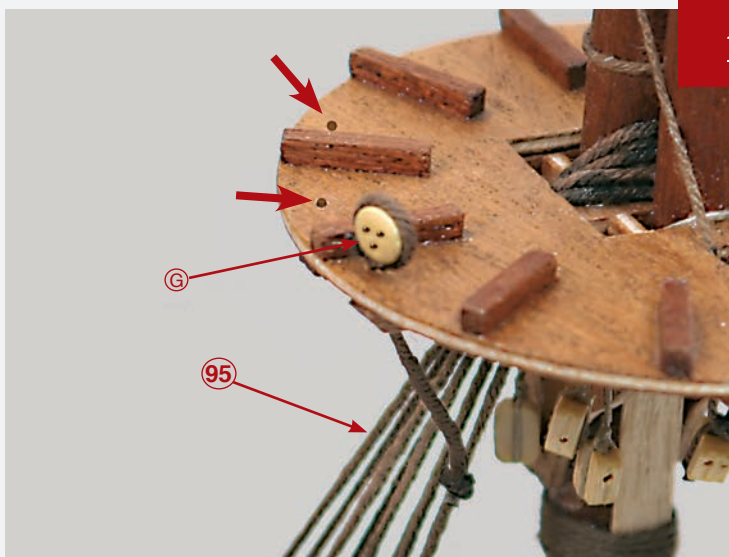

f

Guided by the plan, drill three 1mm holes in the foretop. Cut lengths of thread to make the futtocks, 95 and 98, and fix a G deadeye to the end of each. Then pass the free end into one of the holes in the top and secure to the upper part of the corresponding shroud.

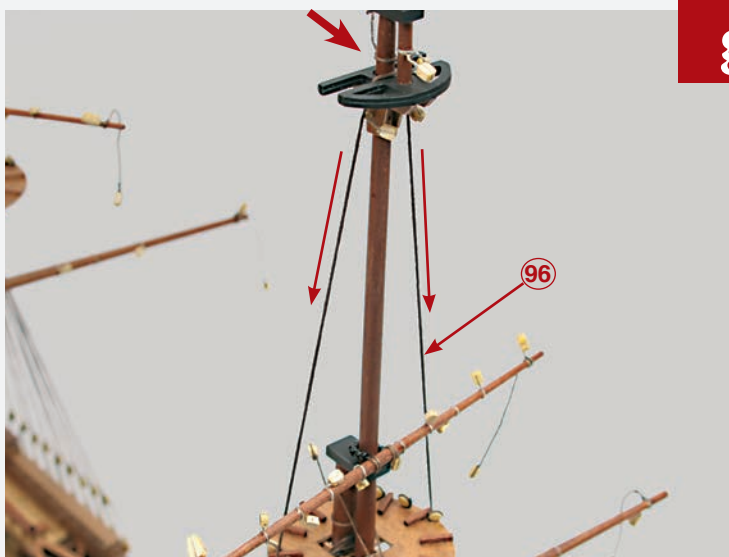

g

To begin rigging the upper fore and mainmast shrouds, 96 and 99, cut lengths of thread to the measurements indicated on the parts list. Pass a thread between the top and the topgallant masts, with either side resting in the gap of the crosstrees. Pull the length of thread to the same length on both sides. Apply glue to the thread of the crosstrees to secure.

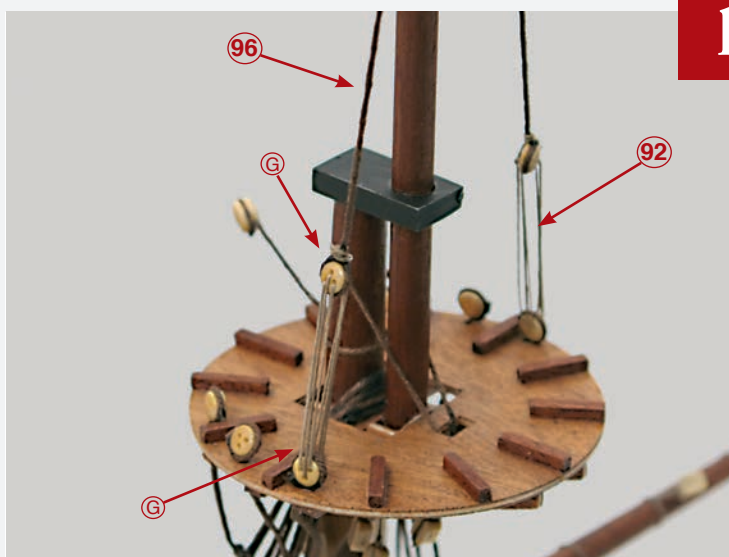

h

Secure a G deadeye at each end of the thread. Connect these deadeyes to those at the top of the foretop with 0.15mm thread (92) in the same way as those in Step d.



i

Repeat Steps f-h to fit the remaining two upper shrouds to the foremast and three upper shrouds to the mainmast.

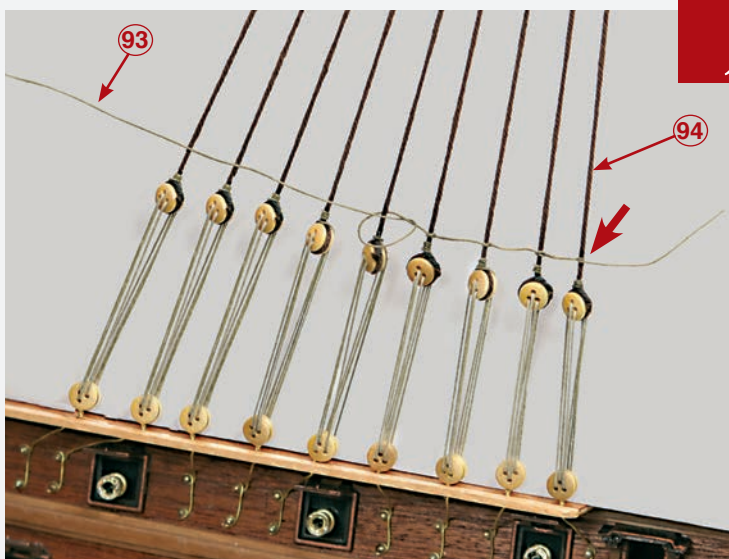

j

To make the ratlines (93), cut a length of 0.15mm natural thread. Tie one end of the thread to the first shroud (arrowed), then to the second, the third and so on, securing each knot with a dab of glue, until you reach the last one.

Referring to figure A on the rigging plan, tie a series of ratlines up the foremast and mainmast shrouds.



k

The photo shows how the assembly should look at this stage. Keep any left-over material, as it will be used later.